



## AC500

### Brazed plate heat exchanger with single and double refrigerant circuit

AC500 is the innovative Alfa Laval brazed heat exchanger that's specifically developed to work in air conditioning, refrigeration, and heat pump applications.

AC500 is a single and double refrigerant circuit unit developed for chillers in the 200-600 kW range; it is suitable to work as an evaporator and a condenser. The innovation is related to the channel plate design and to the distributor. Compared to existing products, it demonstrates a 5% improvement in COP or 20% in cooling capacity.

Our laboratories verified the heat exchanger, and it achieves the highest market performances with HFC refrigerants such as R407C, R404A, R507 (AC500 model), and R410A (ACH500 model) and with natural refrigerants (CO<sub>2</sub> - propane).

Traditionally, Alfa Laval concentrates extensively on reliability. All the brazed heat exchangers in customers' chiller and heat pump installations are subject to daily fatigue cycles during on/off operations. Our mission is to supply reliable products that prevent damage after a few cycle operations and to assure our customers that the units will not create problems. That's why Alfa Laval worked extensively during the last 50 years to design and develop reliable products and continues to invest heavily in R&D.

The AC500 has a patent and a unique integrated distributor pressed together with the plate to assure the highest level of quality and performance reliability. The unit is available with major pressure vessel codes such as PED (Europe), UL (USA), and KHK (Japan).

#### Possible applications

- Evaporator in chiller and heat pumps
- Condenser in chiller and heat pumps



#### Prerequisites

To enable Alfa Laval's representatives to create a quotation, please ensure that they have these specifications:

- Flow rates or heat load required
- Inlet and outlet temperature
- Desired working pressure
- Maximum permitted brine pressure drop
- Connection types
- Brine and refrigerant type

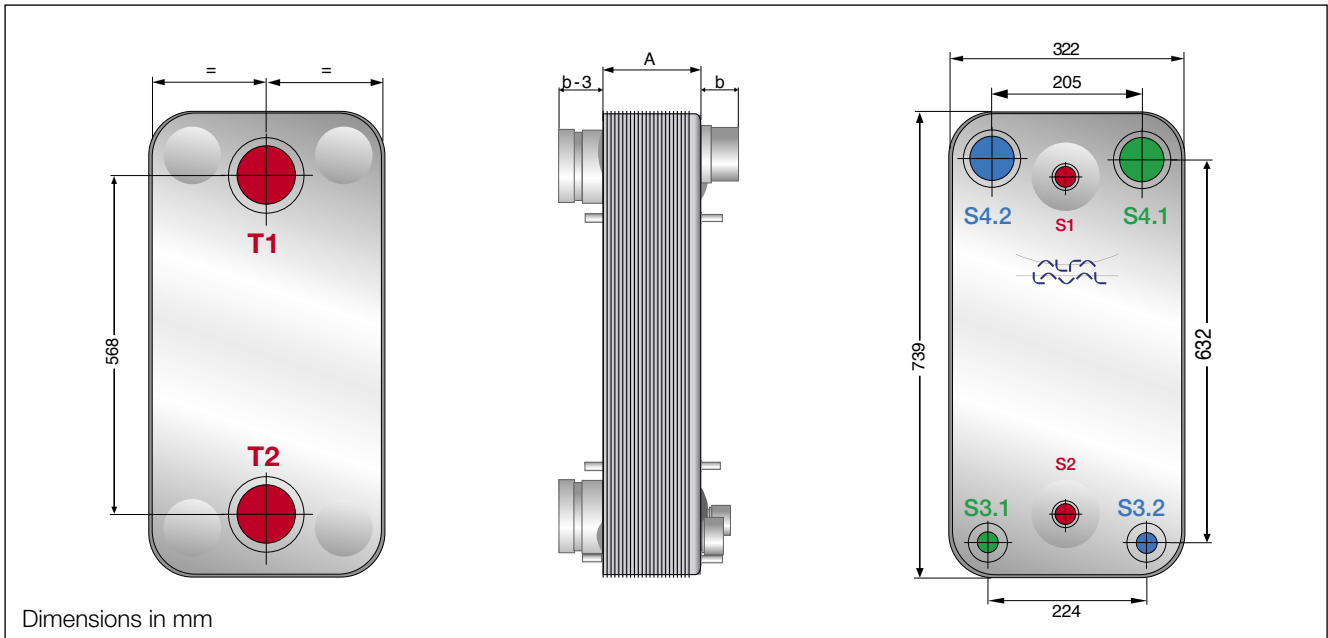

**General data**

Design temperature -160°C / +150°C  
 AC500 design pressure 32 bar  
 ACH500 pressure design 45 bar  
 Maximum flow rate (water side) 105 m³/h

**Standard connections**

Water/brine side S1-S2-T1-T2: 2" 1/2, 3" BSP  
 VICT, 2" 1/2, 3"  
 Refrigerant side S3: 1" 1/8, 1" 3/8  
 S4: 2" 1/8, 2" 5/8, 3" 1/8

**Dimensions**

A = 13 + n x 2.82 (mm)  
 Weight = 13 + n x 0.82 (kg)  
 n = number of plates

**Alfa Laval brazed plate heat exchangers range**

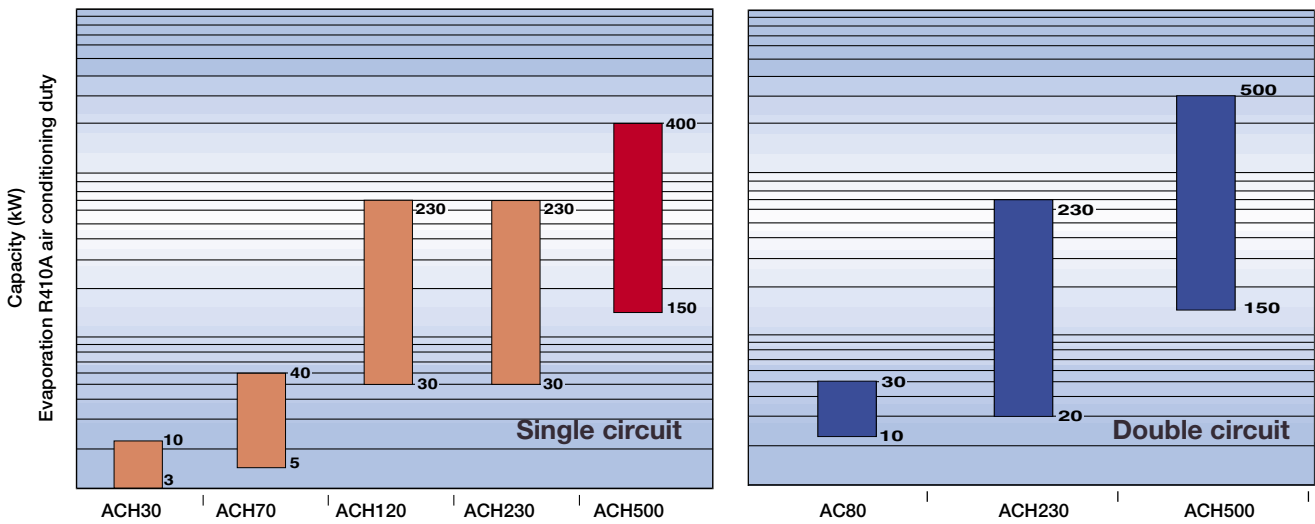

**How to contact Alfa Laval**

Up-to-date Alfa Laval contact details for all countries are always available on our website at [www.alfalaval.com](http://www.alfalaval.com)